

# N41-1 ROPER 3611 - 4722 GEAR REDUCTION UNIT

Attaches to Sizes 11, 17 and 22 GHB Pumps

Three Ratios: 3.20:1 3.94:1 4.60:1

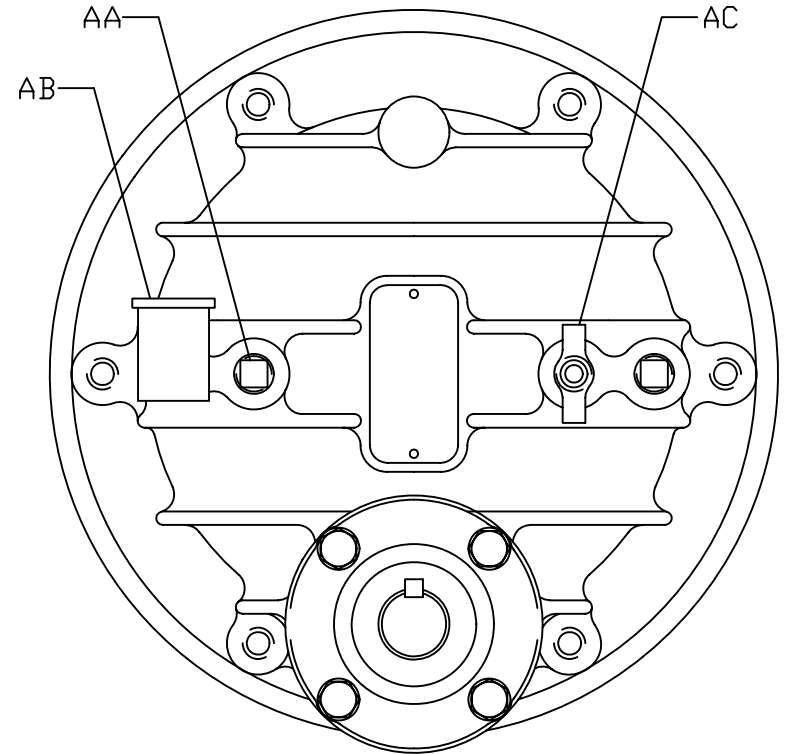
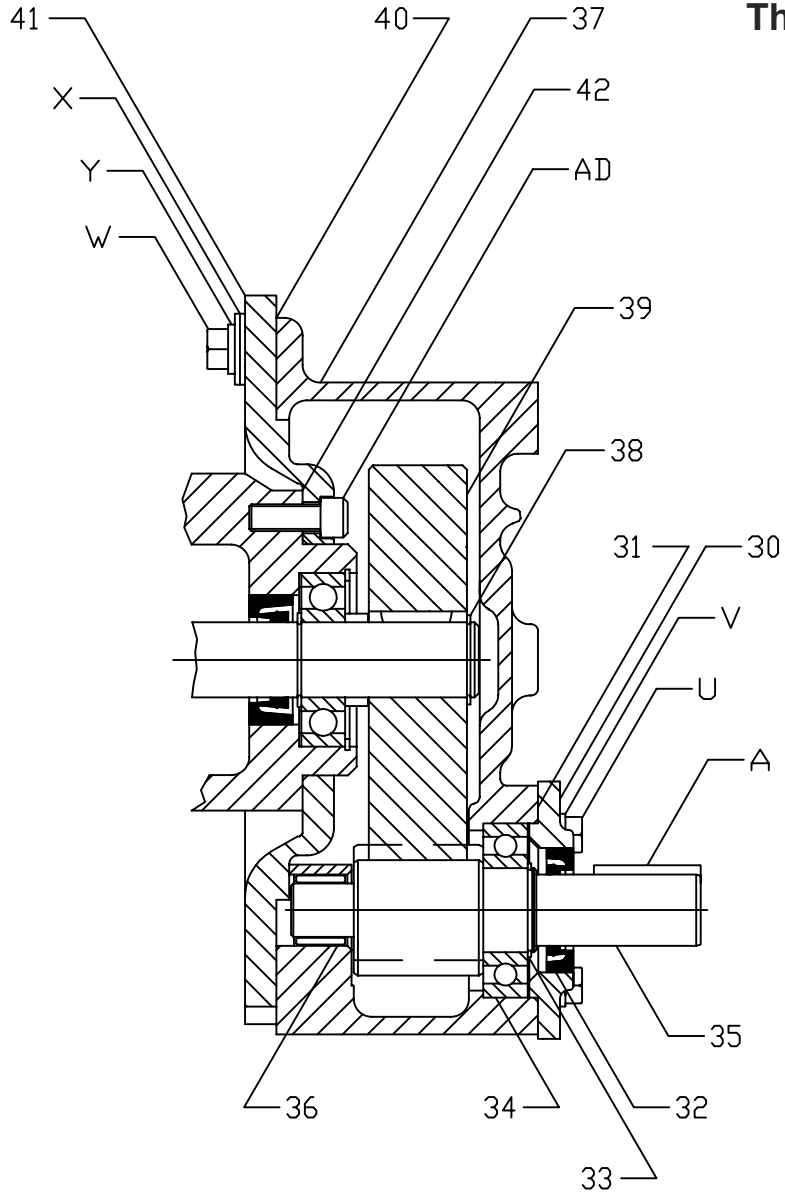

Tank Truck Service & Sales, Inc. Warren, Michigan  
800-482-2678 [www.tanktruckservice.com](http://www.tanktruckservice.com)

## N41-XXX-1

| KEY NO. | DESCRIPTION             | N41-320-1 |            | N41-394-1 |            | N41-460-1 |            |
|---------|-------------------------|-----------|------------|-----------|------------|-----------|------------|
|         |                         | QTY       | PART NO.   | QTY       | PART NO.   | QTY       | PART NO.   |
| 30      | Bearing Retainer        | 1         | P4-384     | 1         | P4-384     | 1         | P4-384     |
| 31      | Bearing Retainer Gasket | 1         | D11-277    | 1         | D11-277    | 1         | D11-277    |
| 32      | Lip Seal                | 1         | D83-22     | 1         | D83-22     | 1         | D83-22     |
| 33      | Retaining Ring          | 1         | G41-78     | 1         | G41-78     | 1         | G41-78     |
| 34      | Ball Bearing            | 1         | G40-10     | 1         | G40-10     | 1         | G40-10     |
| 35      | Pinion Gear and Shaft   | 1         | D37-120    | 1         | D37-117    | 1         | D37-115    |
| 36      | Needle Bearing          | 1         | G40-30     | 1         | G40-30     | 1         | G40-30     |
| 37      | Gear Case               | 1         | P49-2      | 1         | P49-2      | 1         | P49-2      |
| 38      | Retaining Ring          | 1         | G41-76     | 1         | G41-76     | 1         | G41-76     |
| 39      | Drive Gear              | 1         | D37-64     | 1         | D37-67     | 1         | D37-69     |
| 40      | Gear Case Gasket        | 1         | D11-278    | 1         | D11-278    | 1         | D11-278    |
| 41      | Gear Box Cover          | 1         | P22-13     | 1         | P22-13     | 1         | P22-13     |
| 42      | Cover Gasket            | 1         | D11-276    | 1         | D11-276    | 1         | D11-276    |
| A       | Drive Key               | 1         | D30-9      | 1         | D30-9      | 1         | D30-9      |
| AA      | Pipe Plug               | 2         | G56-12     | 2         | G56-12     | 2         | G56-12     |
| AB      | Oil Cup                 | 1         | G61-239    | 1         | G61-239    | 1         | G61-239    |
| AC      | Petcock                 | 1         | G61-71     | 1         | G61-71     | 1         | G61-71     |
| AD      | Socket Head Cap Screw   | 4         | G45-037100 | 4         | G45-037100 | 4         | G45-037100 |
| U       | Hex Head Cap Screw      | 4         | G49-031075 | 4         | G49-031075 | 4         | G49-031075 |
| V       | Lockwasher              | 4         | G8-71      | 4         | G8-71      | 4         | G8-71      |
| W       | Hex Head Cap Screw      | 6         | G49-037125 | 6         | G49-037125 | 6         | G49-037125 |
| X       | Flat Washer             | 12        | G8-52      | 12        | G8-52      | 12        | G8-52      |
| Y       | Lockwasher              | 6         | G8-72      | 6         | G8-72      | 6         | G8-72      |

**Note:**

The only two parts that are different in all three gear reduction units are #35 Pinion Gear and Shaft, and #39 Drive Gear. Be sure of the gear ratio you want parts for - 3.20:1; 3.94:1; or 4.60:1.

Pinion and Drive Gears are matched for each ratio and must be used together as a set, ie.; you can't use a 3.20:1 Pinion and a 3.94:1 Drive Gear.